

GORILLA SPORTS

MANUAL FOR PRESS BENCH

(10000118)

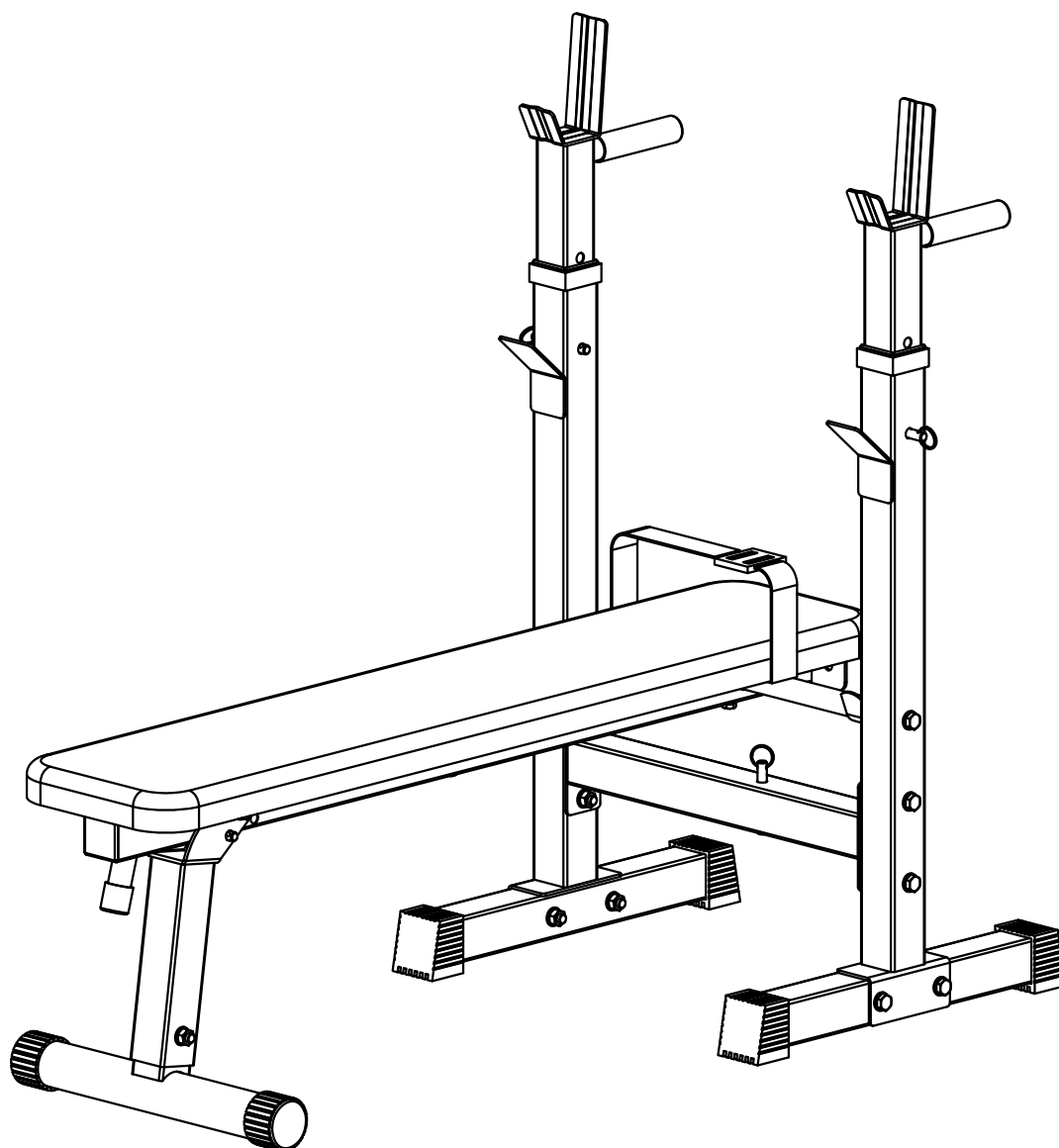



GORILLA SPORTS

PROFESSIONAL GYM EQUIPMENT FOR EVERYONE

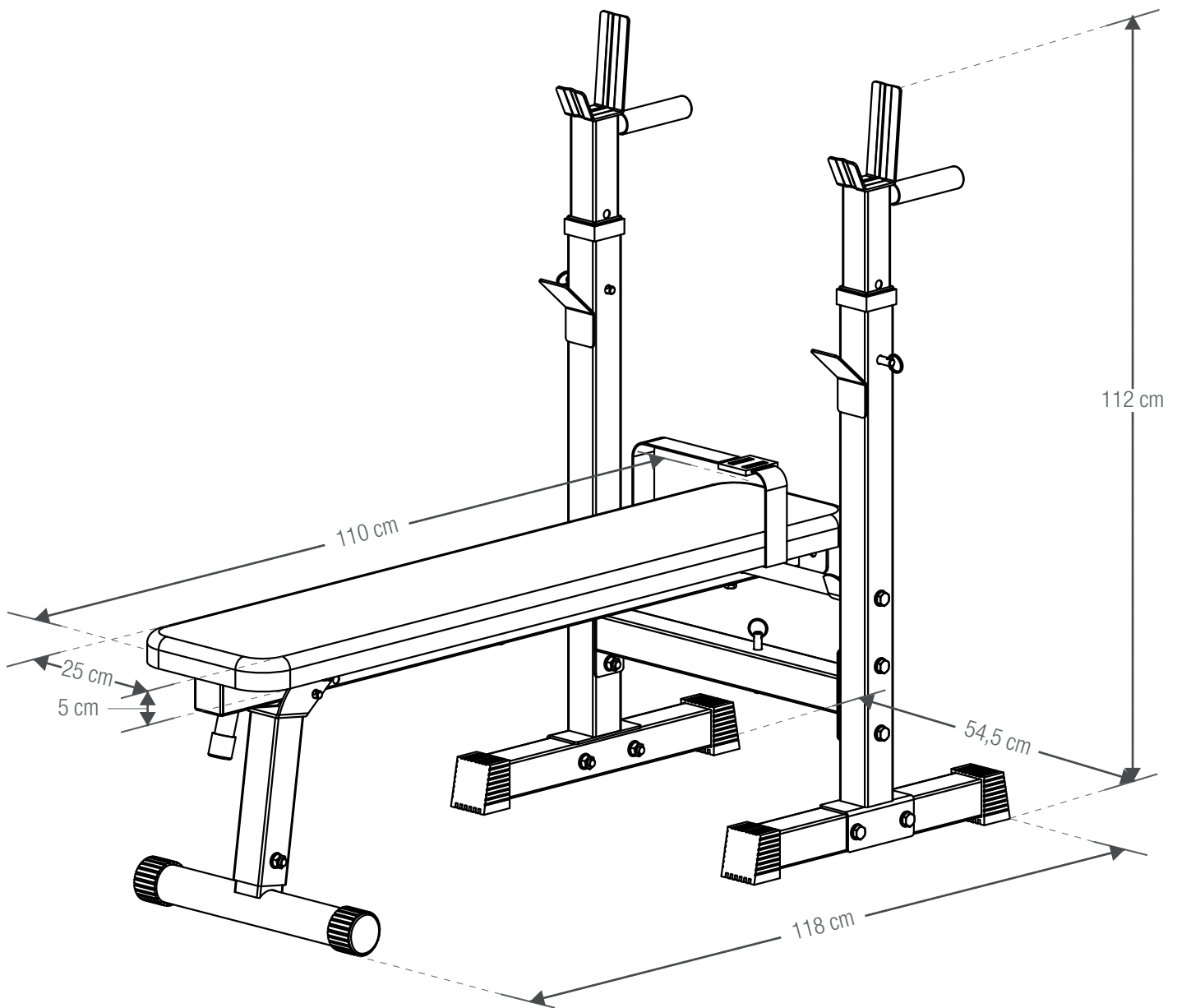

Maximum load: 200 kg



GORILLA SPORTS

Washer: ($\phi 10$)

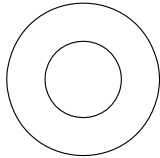

22x

Nut: (M10)

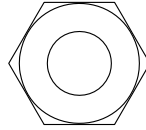

10x

Washer: ($\phi 8$)

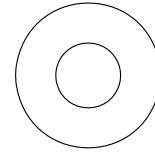

3x

Bolt: (M10*75)

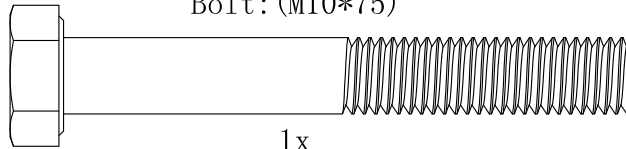

1x

Bolt: (M10*67)

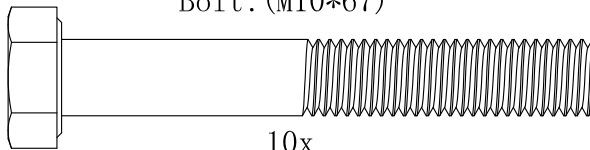

10x

Bolt: (M8*50)

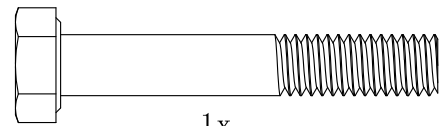

1x

Bolt: (M10*65)

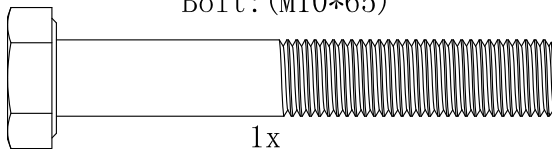

1x

Bolt: (M8*65)

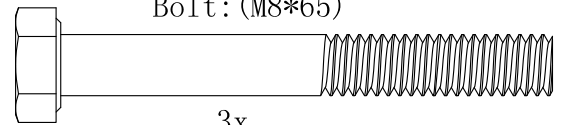

3x

Spanner

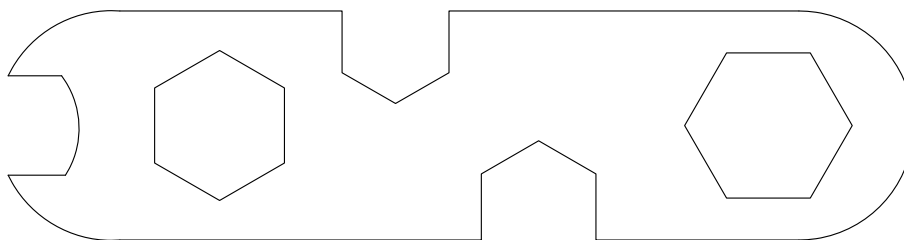

2x

Inside PAN-HEAN Bolt: ($\phi 10*65$)

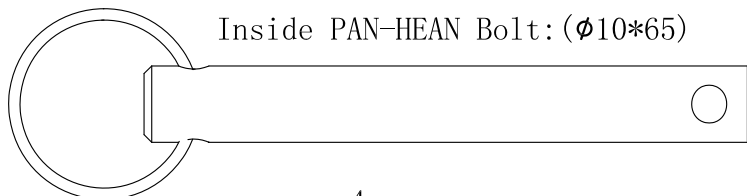

4x

1

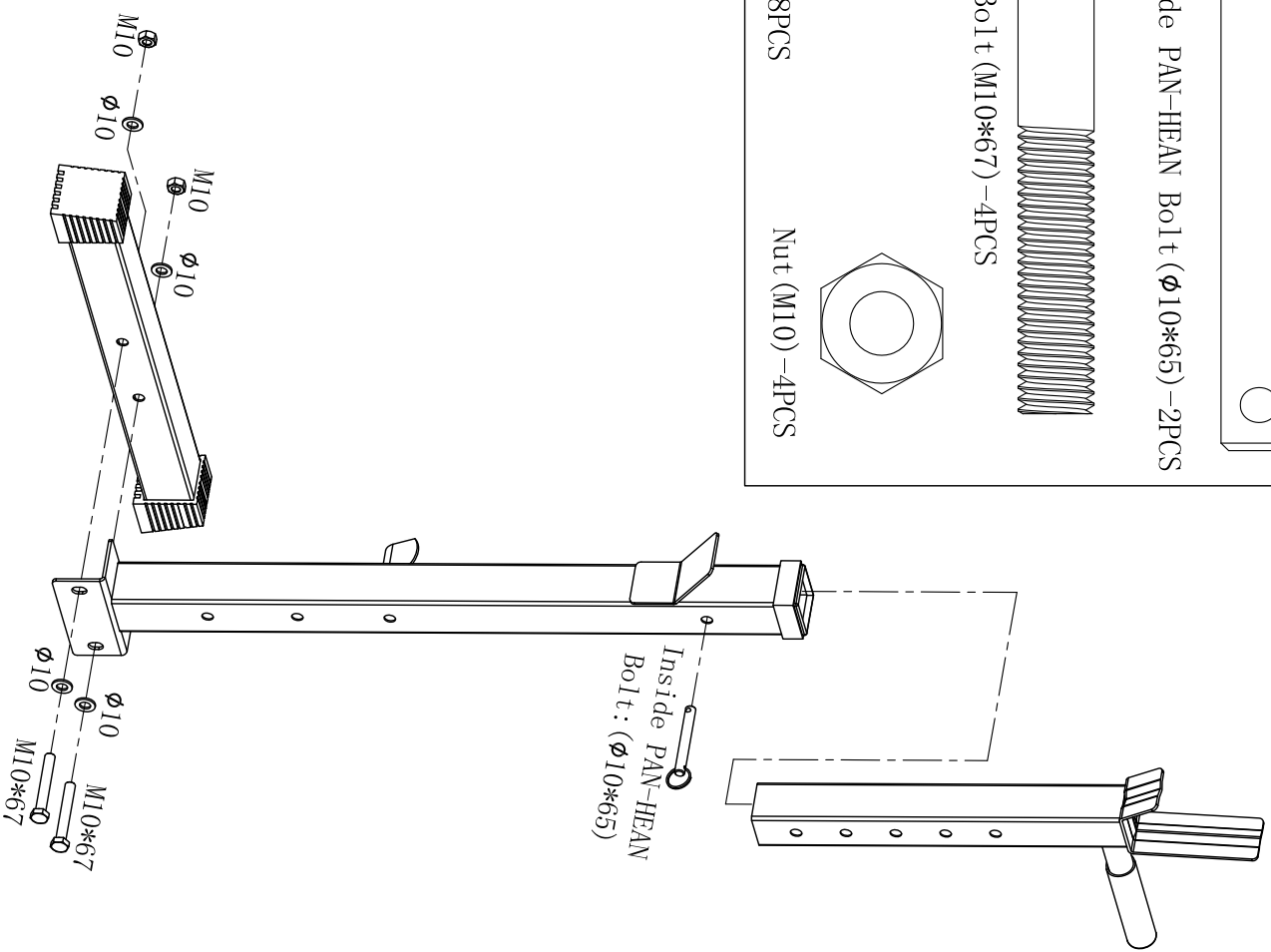
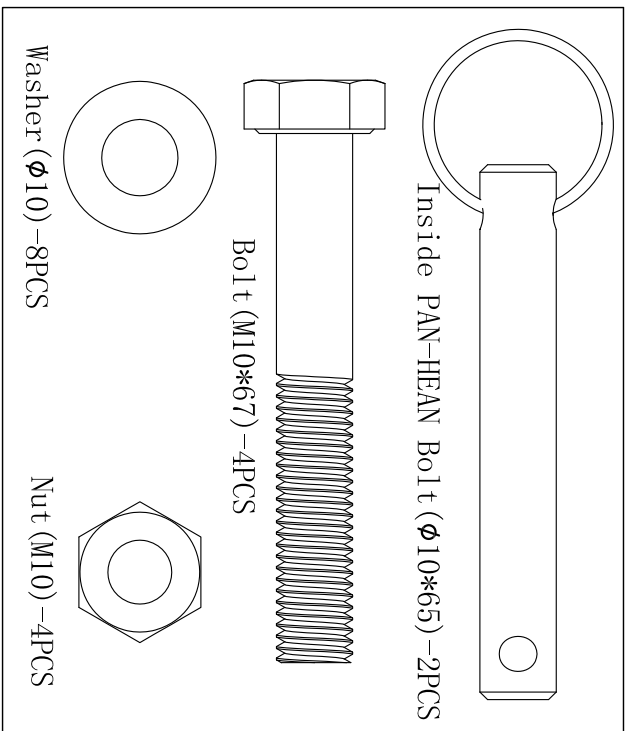
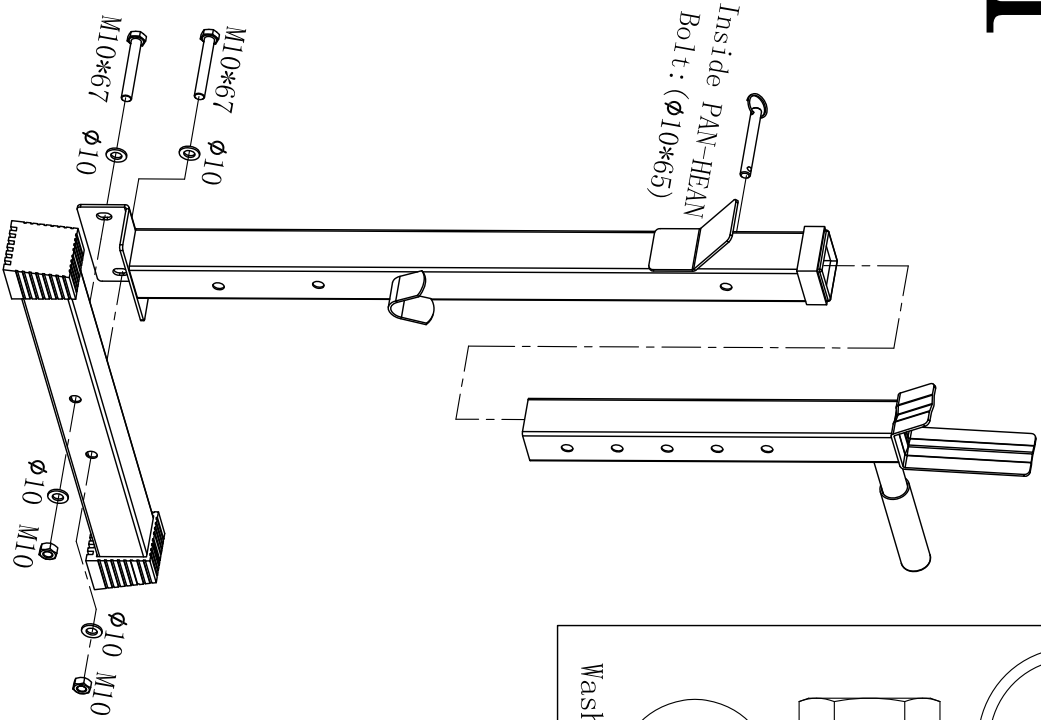

2

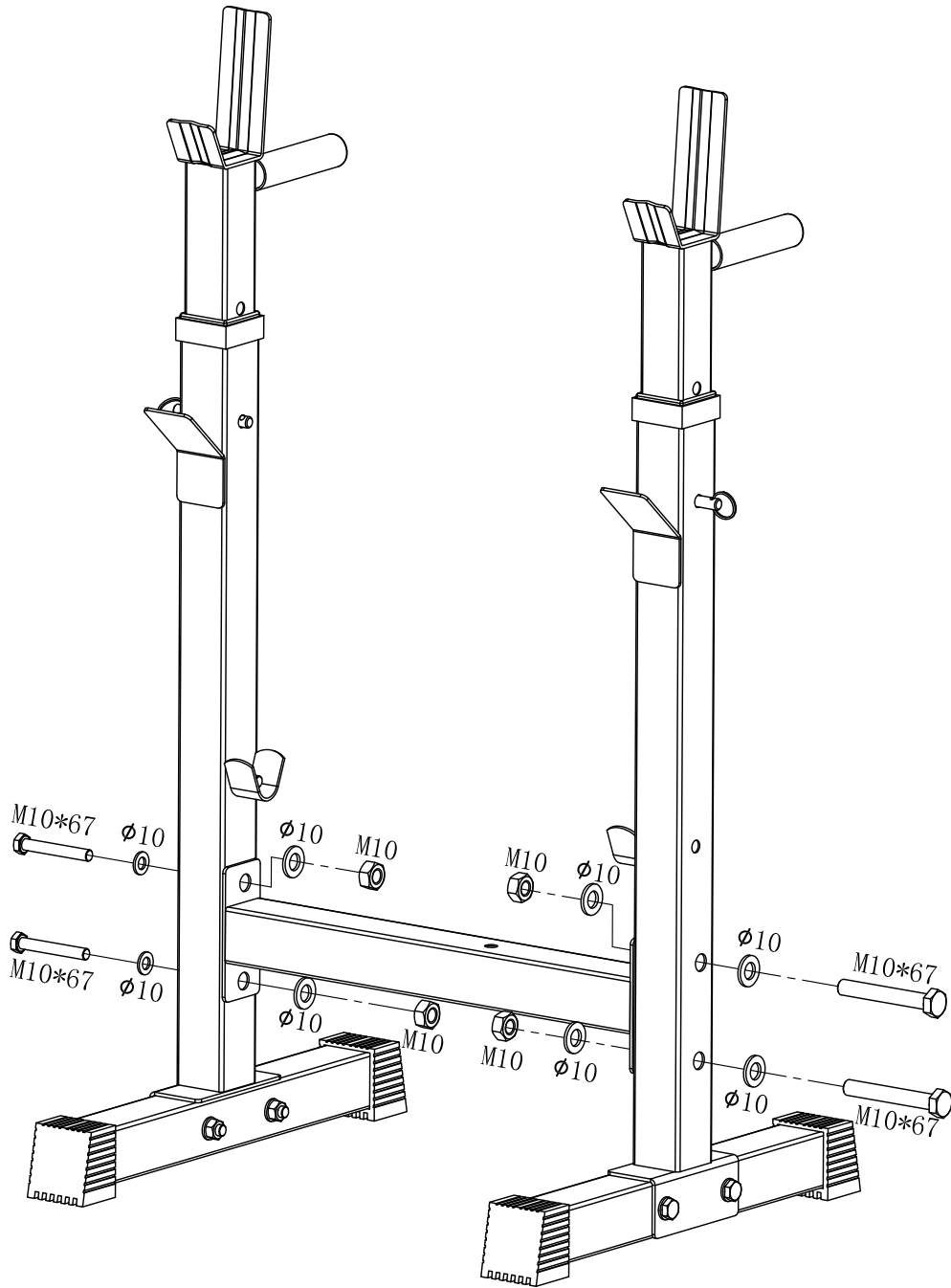
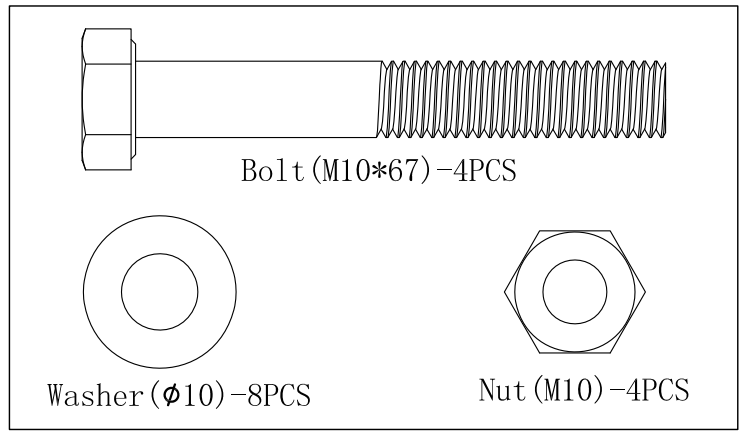

3

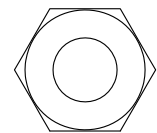
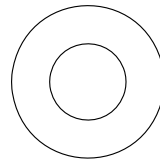
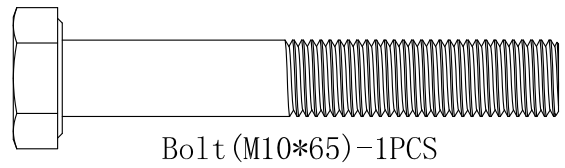
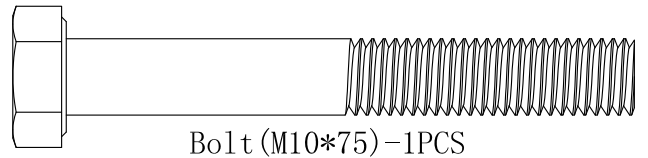
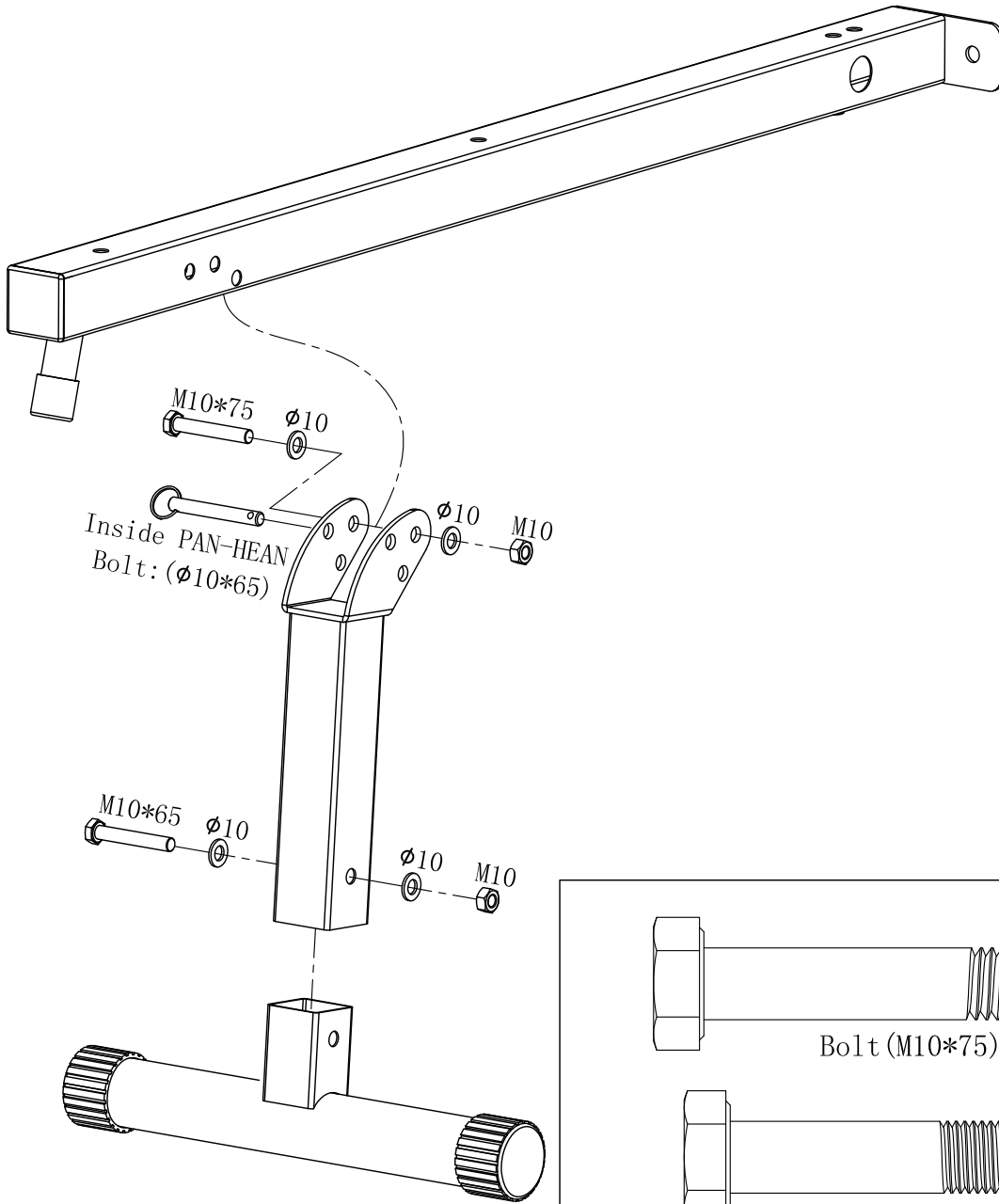

Washer ($\phi 10$) - 4PCS

Nut (M10) - 2PCS



4

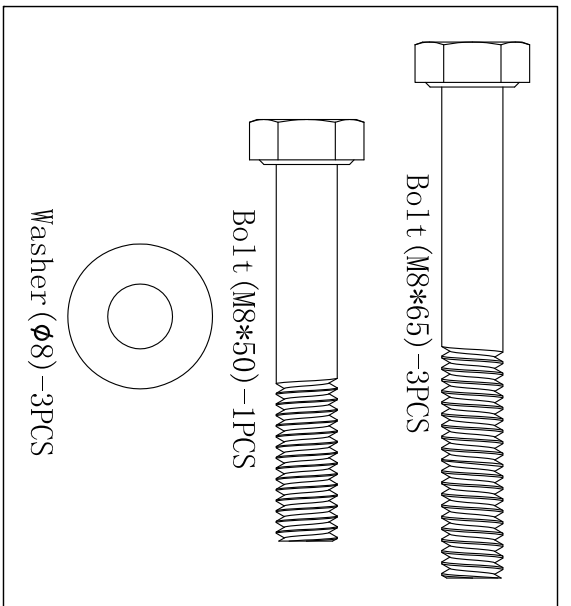
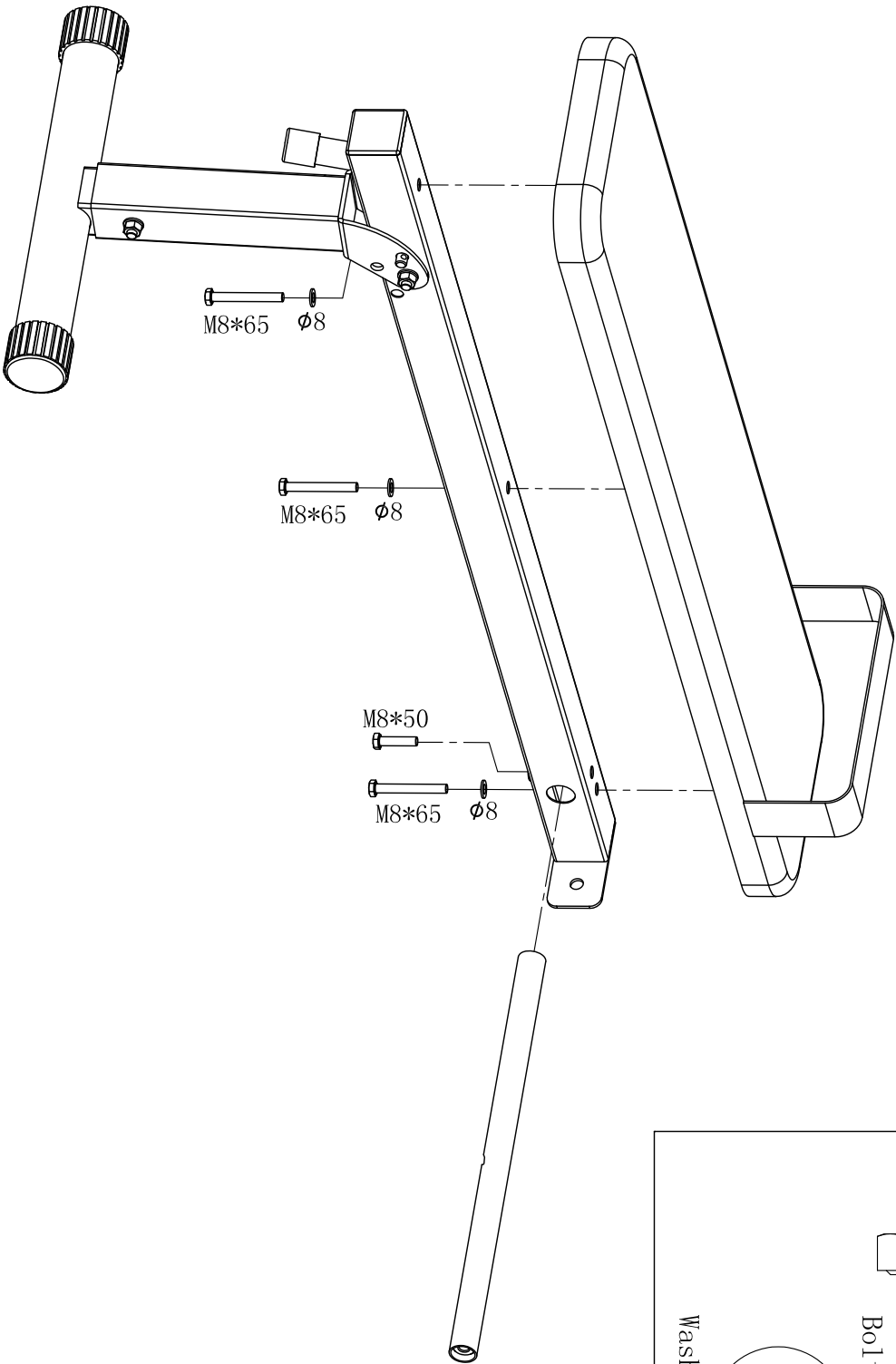

5

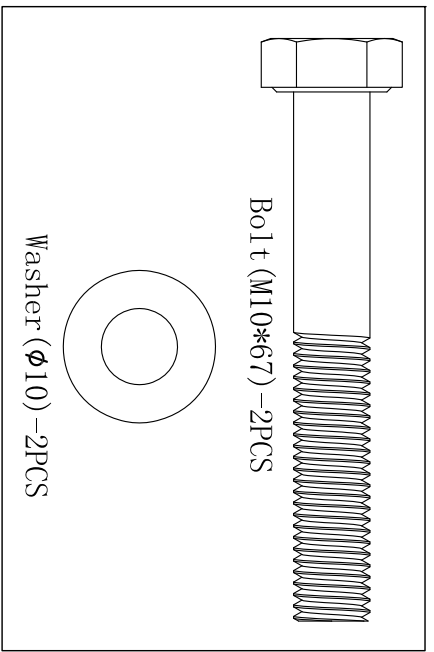
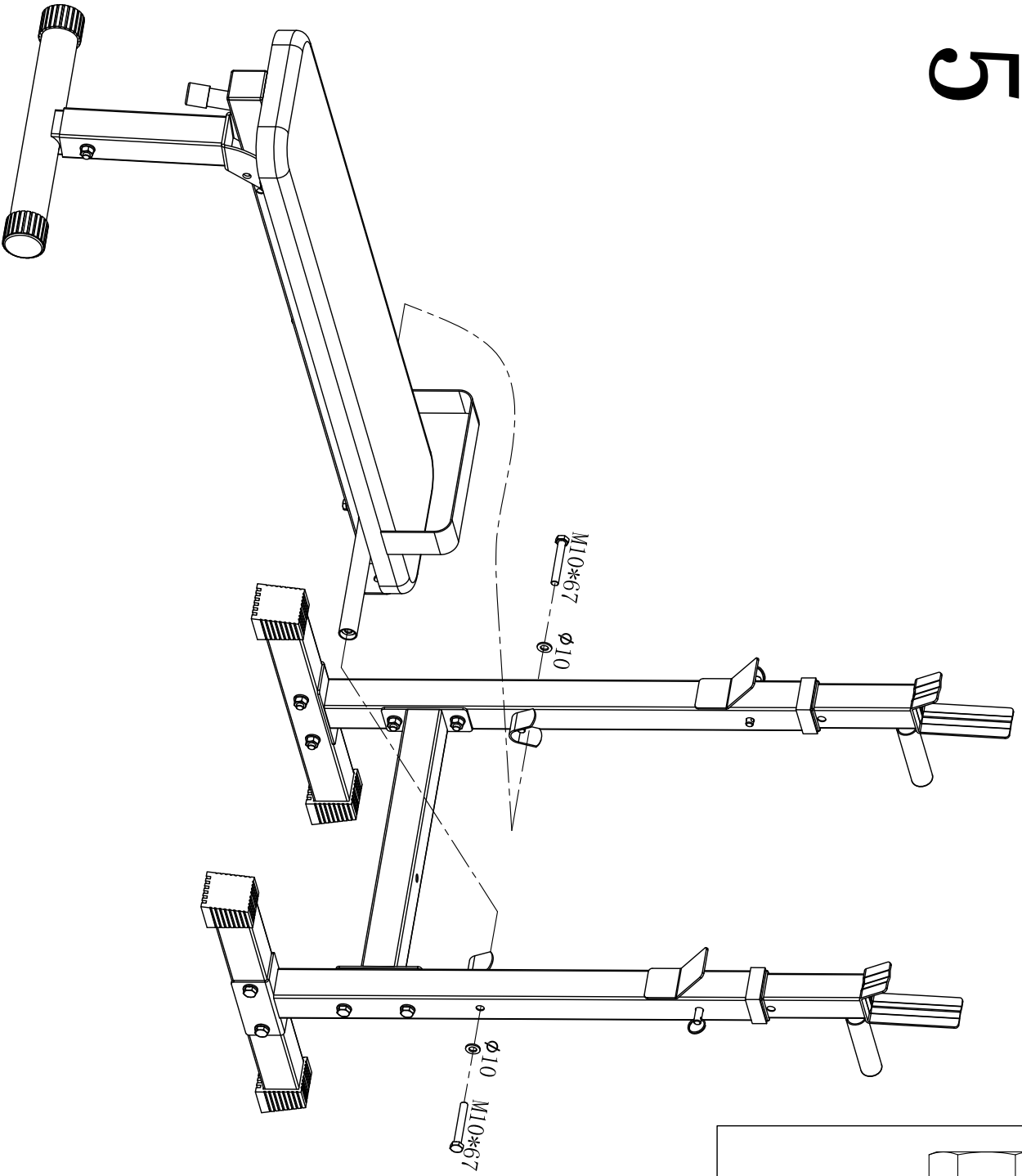

6

